

GLOBAL

ZZ 509
Instruction manual

CONTENTS

1.Application	1
2.Notes on safety	1
3.Commissioning	1
4.Installing the belt guard	2
5.Lubrication	2
6.Needle and thread	3
7.Inserting the bobbin case	3
8.To remove the bobbin case	3
9.To wind the bobbin	4
10.Threading the bobbin case	4
11.To replace the bobbin case	5
12.Threading the needle	5
13.To adjust stitch length	5
14.To adjust presser foot pressure	6
15.To adjust needle thread tension	6
16.Regulating the take-up spring	6
17.To adjust bobbin thread tension	6
18.Needle position selector	6
19.Stitch width regulator	7
20.How to control the width of zigzag stitch	7
21.Needle bar frame clamping device	7
22.Fittings for straight and zigzag stitching	8
23.Changing the throat plate and feed dog	8
24.To mount thread unwinder	8
25.To use the spool cap	9
26.To use the anti-spill sleeve	9
27.Knee lifter	9
To mount knee lifter	9
Knee operating presser foot lift	10
Knee operating stitch width control	10
28.Fittings for buttonhole stitching	11
29.Fittings for hem sewing	11
30.Fittings for zipper and cord sewing	11
31.Caring for your machine	11
32.Troubleshooting chart	12
33.Specifications	13

1. APPLICATION

This kind of Artisan Zigzag Machine is for;

- Zigzag and ornamental stitching in a variety of width and stutch length.
- Perfect straight stitching
- Superfine control of stitch length insures perfect satin stitching.

This machine is manufactured for artisan zigzag sewing and is suited for sewing light weight and medium weight materials.

2. NOTES ON SAFETY

The machine must only be commissioned in full knowledge of the instruction manual and operated by persons with appropriate training.

Before putting into service, also read the safety notes and the instruction manual of the motor supplier.

The machine must be used only for the purpose intended. Use of the machine without the safety devices belonging to it is not permitted.

When gauge parts are exchanged (e.g. needle, presser foot, needle plate, feed dog and bobbin), during threading, when the workplace is left unattended, and during service work, the machine must be isolated from the mains by switching off the main switch or disconnecting the mains plug.

On mechanically operated clutch motors without start inhibitor, it is necessary to wait until the motor has stopped.

General servicing work must be carried out only by appropriately trained persons.

Repairs, conversion and special maintenance work must only be carried out by technicians or persons with appropriate training.

Work on the electrical equipment must be carried out only by electricians or appropriately trained persons.

Conversions or changes to the machine must be made only on adherence to all safety regulations.

For repairs, only replacement parts approved by us must be used.

Meanings of the symbols:

Danger spot!
Items requiring special attention



Danger of injury to operative or service staff.

Be sure to observe and adhere to these safety notes!



Earth



3. COMMISSIONING



To avoid disturbances or damages, it is absolutely necessary to observe the following instructions:

Before you put the machine into operation for the first time, clean it thoroughly and oil it well (see page 2).

Have the mechanic check whether the motor can be used with existing mains voltage or not, and that junction box is correctly connected. Do not start the machine if the voltage is not correct!

When the machine runs, the balance wheel must rotate toward the operator. If it does not, have the electrician change the wires on the motor.

4. INSTALLING THE BELT GUARD

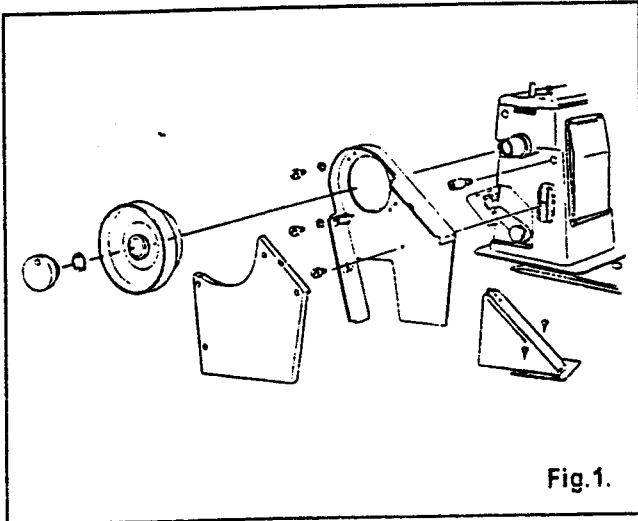

Fig. 1.

		<h3>CAUTION</h3>
<p>Switch off the machine. Set sewing head upright again using both hands. Danger of crushing between sewing head and table top. Do not run machine without belt guard! Danger of accidents!</p>		

Above table surface

Align the belt guard so that hand wheel and V-belt move freely, then screw it down in this position. (See Fig. 1)

Below table surface

Install belt guard so that motor pulley and V-belt will rotate freely without interference.

5. LUBRICATION

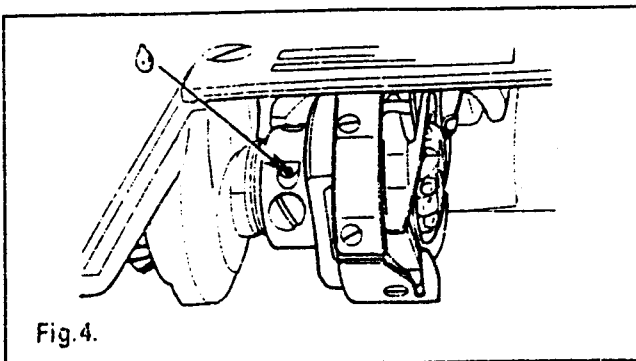

Fig. 4.

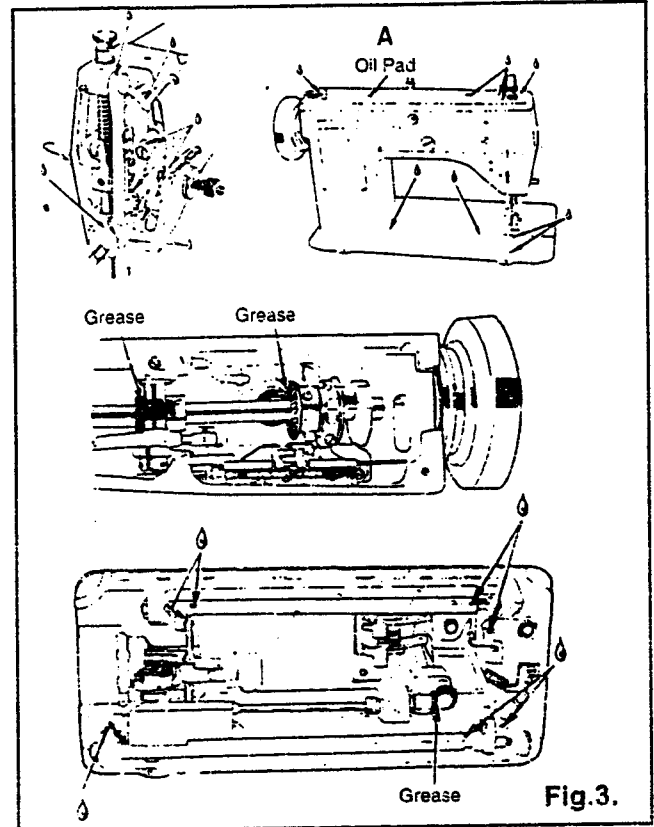

Fig. 3.

		<h3>CAUTION</h3>
<p>Switch off the machine. Set sewing head upring again using both hands. Danger of crushing between sewing head and table top.</p>		

- Rotating hook and area under throat plate.
Turn hand wheel over toward you until oil hole in rotating hook appears in sight.
Apply one or two drops of oil to the oil hole. (See Fig. 2)

Loosen and remove screws and remove face plate by sliding it downward.

Remove screws and lift off arm top cover.
Clean and oil the places indicated.

Apply sufficient oil to all oil felt shown in Fig. 3.
Apply a small amount of grease to gear teeth indicated with word 'Grease' in Fig. 3.

Also apply a drop of oil to all other oiling points shown with marks

Keep oil pad (A) under arm top cover saturated with oil.

CHOICE OF OIL

No. 2 White Lubricant or HJ-7 Mechanical oil must be used.

6. NEEDLE AND THREAD

Selection of the proper needle depends not only on the machine model, but also on the material and thread used. For selection of proper needle and thread sizes to be used on the various machine models please refer to the table below.

Machine class	ZZ 509		
Application of class	For light-weight materials	For medium-weight materials	For medium-heavy weight materials
Max. thread size(Nm)-Synthetic*	120	60	30
Needle size (1/100 mm)	10	12~16 (80~100)	18~19 (110~120)
Needle catalog (Needle system)	1910-05 (135 x 9)		
*or an equivalent size of other types of thread			

7. INSERTING THE NEEDLE

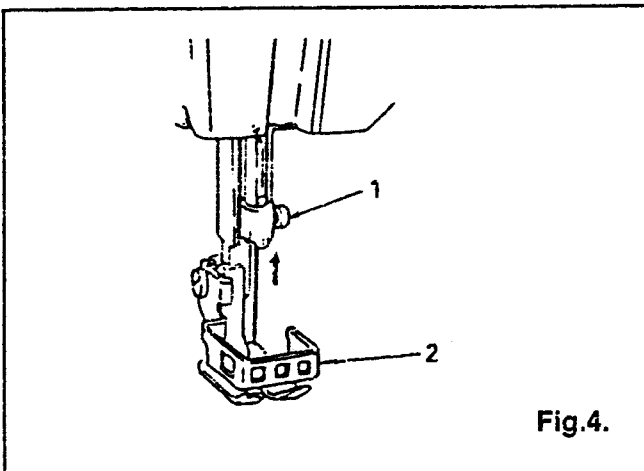
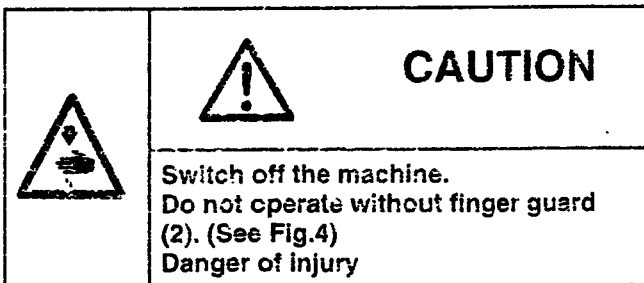

Fig.4.



Use needle cat. No. 1910-05 needle system (135 X 9) only.

Raise needle bar to its highest position by turning hand wheel toward you.

Loosen needle set screw (1), Fig. 4 Inset the needle in the needle bar and push it up as far as it will go.

Make sure its long groove faces toward the front. Tighten needle set screw (1) securely

8. TO REMOVE THE BOBBIN CASE

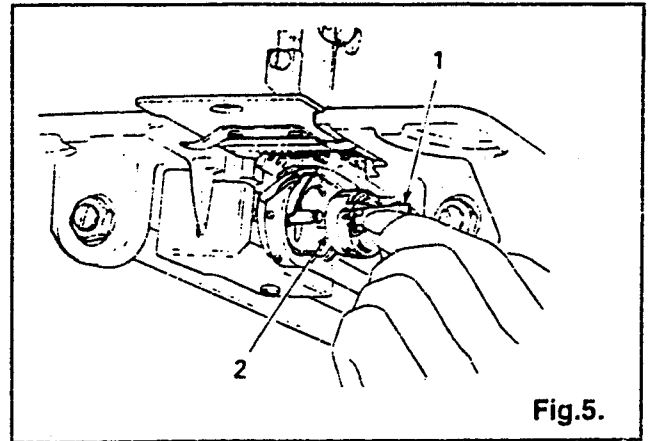
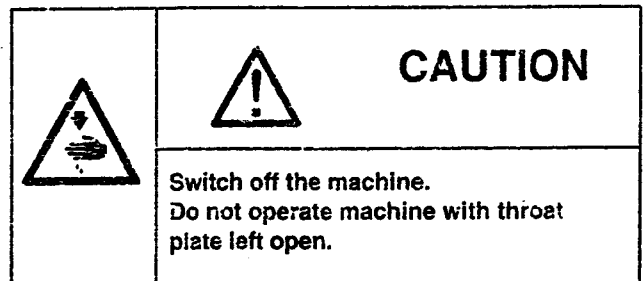

Fig.5.



1. Open bed slide.
2. Raise latch (1), Fig.5.
3. Lift out bobbin case (2), Fig.5.

9. TO WIND THE BOBBIN

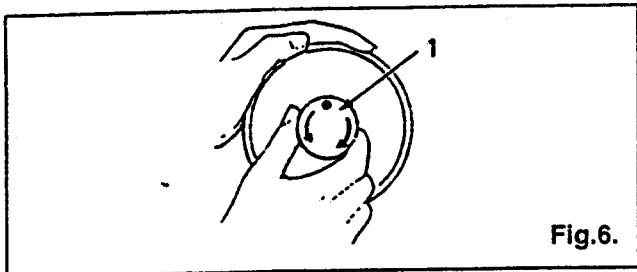

Fig. 6.

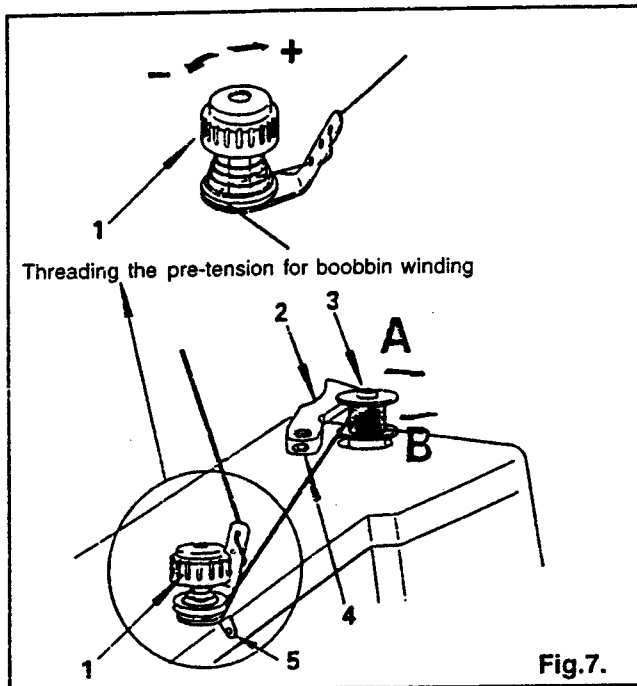

Fig. 7.

CAUTION	
Do not guide or hold thread when winding the bobbin.	

1. Stop motion needle by loosening stop-motion screw (1), Fig. 6. Hold hand wheel with left hand and turn stop-motion screw toward you with right hand.
2. Place bobbin on bobbin winder spindle (3), Fig. 7, pushing it on as far as it will go. Pre-tension (1) (See Fig. 7)
 - +.....More tension.
 -Less tension.
3. Push latch (2) in the direction indicated by arrow (A), then start the machine. (See Fig. 7)

Bobbin winder spindle (3) rotates in the direction indicated by arrow (B). (See Fig. 7)

To adjust the amount of thread on bobbin, loosen screw (4) on latch (2) and swing the latch (2) away from you or toward you, as required.

For more thread on bobbin, swing latch (2) away from you or toward you, as required.

For less thread on bobbin, swing latch (2) toward you. If thread winds unevenly on bobbin, loosen screw (5) and move pre-tension (1) up or down, as required, and tighten screw (5).

10. THREADING THE BOBBIN CASE

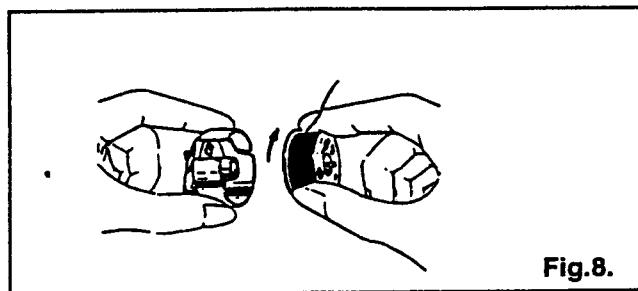

Fig. 8.

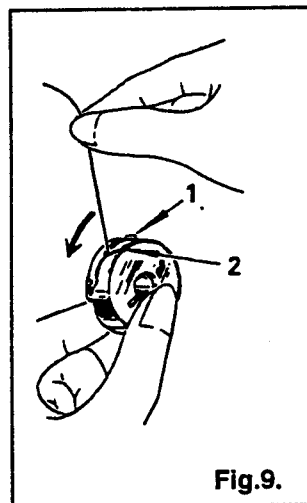

Fig. 9.

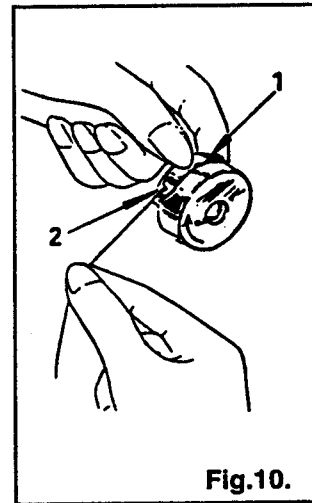
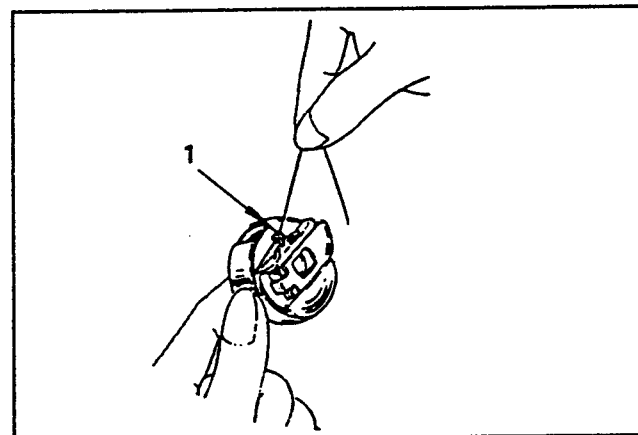

Fig. 10.



1. Hold bobbin case so that thread unwinds in the direction shown in Fig. 8. and put bobbin in bobbin case.
2. Pull thread into notch (1), and draw it under tension spring (2), Fig. 9.
3. Draw thread out from slot (2) on end of spring (1), Fig. 10 and pass it through bobbin case thread guide (1), Fig. 11. Allow about 4 inches of thread to hang freely from bobbin.

NOTE: When straight stitching, a better result can be obtained if bobbin thread is not threaded through bobbin case thread guide (1), Fig. 11.

11. TO REPLACE THE BOBBIN CASE

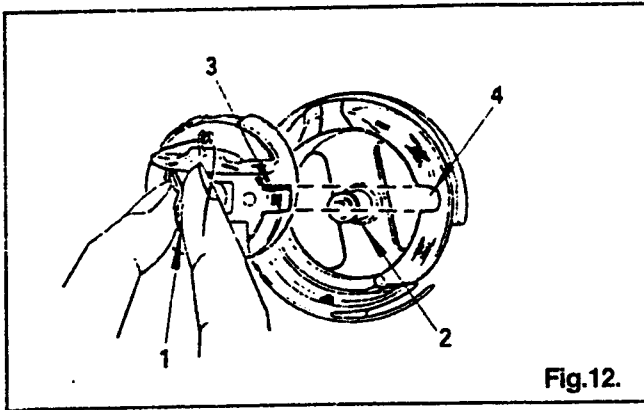
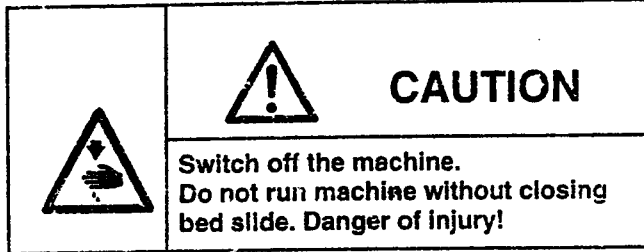

Fig.12.



hold bobbin case by latch (1) and place it on spindle of bobbin case holder (2) so that position finger (3) enters notch (4) at right of bobbin case holder. (See Fig.12) Release latch and press bobbin case firmly in place to assure proper position. Close bed slide.

12. THREADING THE NEEDLE

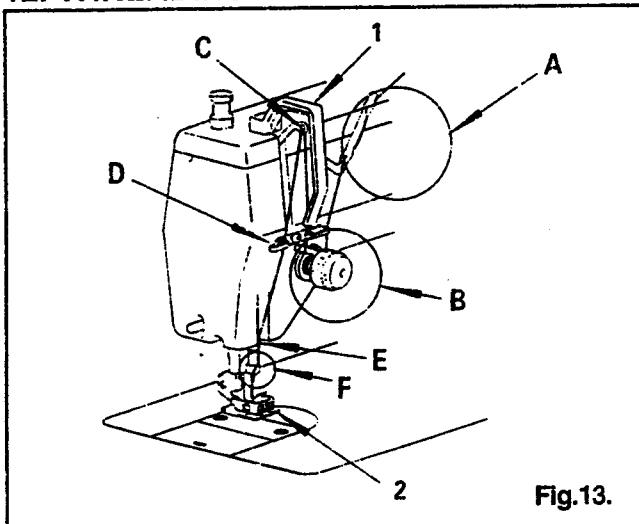

Fig.13.

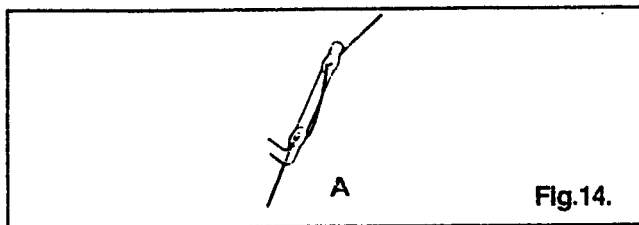

Fig.14.

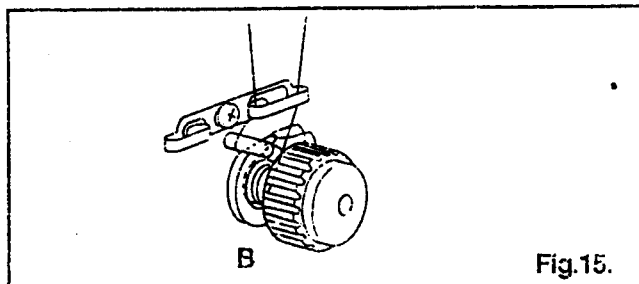

Fig.15.

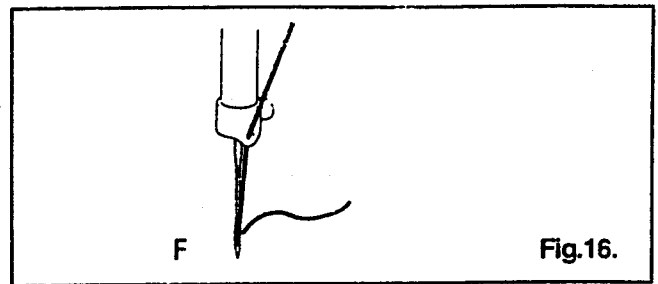
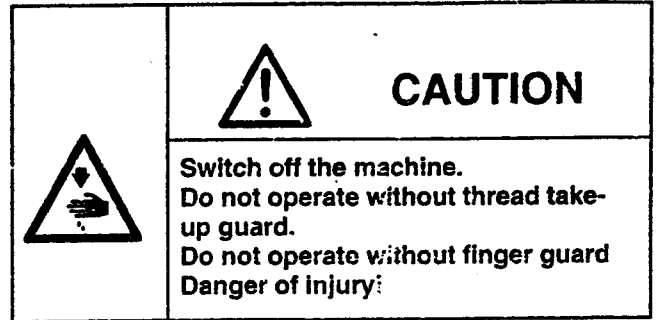

Fig.16.



1. Lead thread from the thread unwinder through all the threading points A (Fig.14), B (Fig.15), C (Fig.13), D (Fig.13), E (Fig.13) and F (Fig.15) in the order shown.
2. Thread the needle from front to back, as shown in Fig.16
3. Draw about 3 inches of thread through eye of needle.

13. TO ADJUST STITCH LENGTH

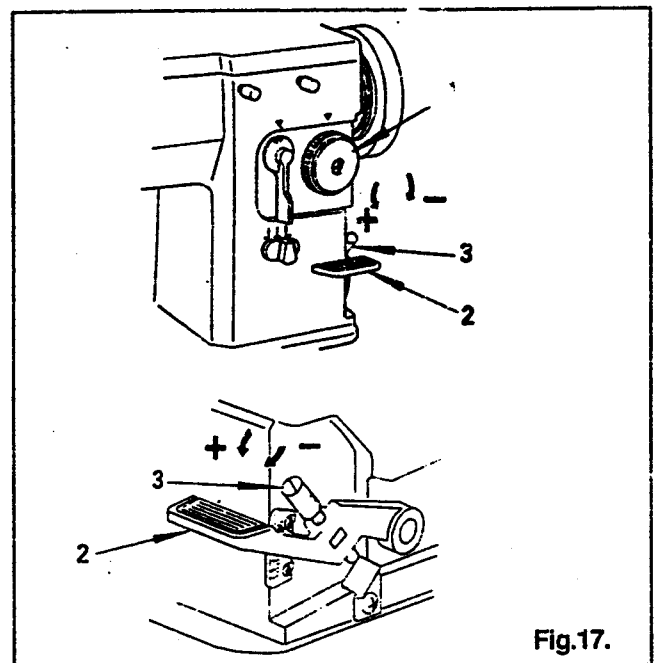

Fig.17.

Regulating the stitch length:

To regulate the stitch length, turn feed regulating dial (1), Fig.17, toward left or right as required.

- +....To lengthen
-To shorten

Changing to reverse feed:

Push lever (2), Fig.17, down for reverse feed and release for forward feed.

To regulate the reverse stitch length, turn thumb screw (3), Fig.17 toward left or right as required.

- +....To lengthen
-To shorten

14. TO ADJUST PRESSER FOOT PRESSURE

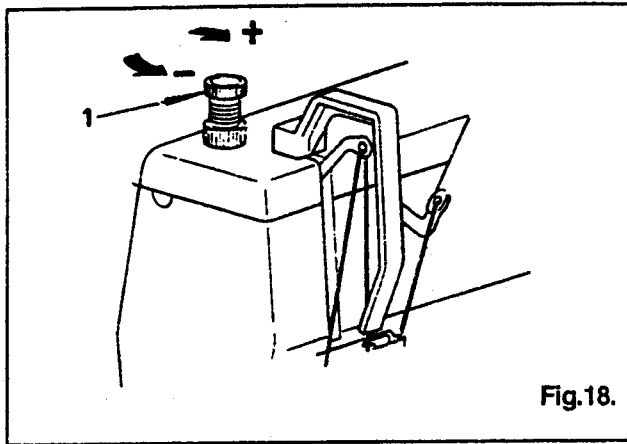

Fig.18.

To regulate the presser foot pressure, turn knurled thumb screw (1), Fig. 18, toward left of right as required.

- +....More pressure
-Less pressure

15. TO ADJUST NEEDLE THREAD TENSION

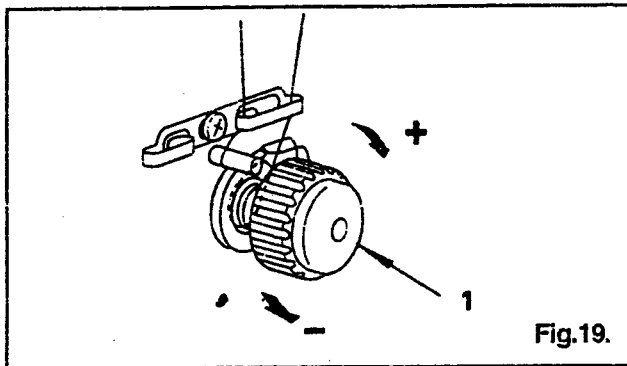

Fig.19.

Regulate needle thread tension with tension regulating knob (1), Fig. 19.

- +....More tension
-Less tension

16. REGULATING THE TAKE-UP SPRING

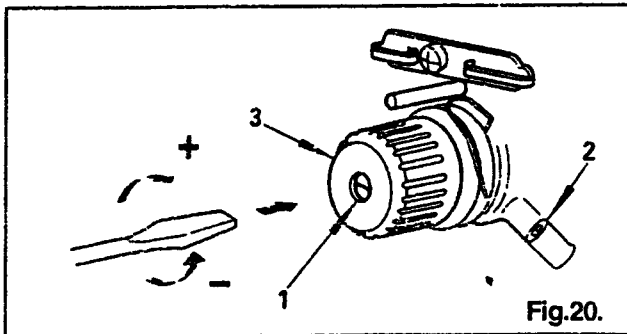

Fig.20.

Using a screwdriver in slot of stud (1), Fig. 20, regulate take-up spring tension by turning stud (1), as required.

- +....More tension
-Less tension

To adjust the amount of take-up spring movement, loosen screw (2), Fig. 20, and set take-up spring height by turning the entire tension assembly (3) toward left or right, as required. Securely tighten screw (2).

17. TO ADJUST BOBBIN THREAD TENSION

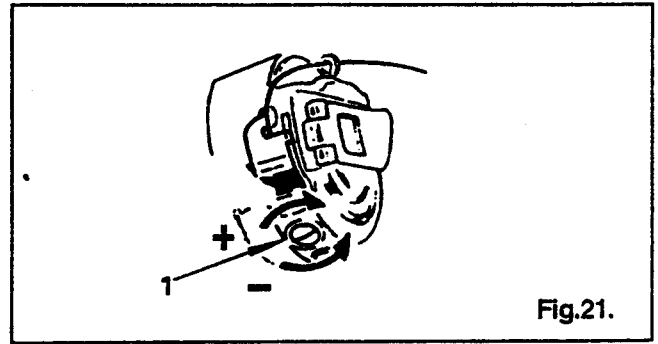

Fig.21.

Regulate bobbin thread tension with tension regulating screw (1), Fig. 19.

- +....More tension
-Less tension

18. NEEDLE POSITION SELECTOR

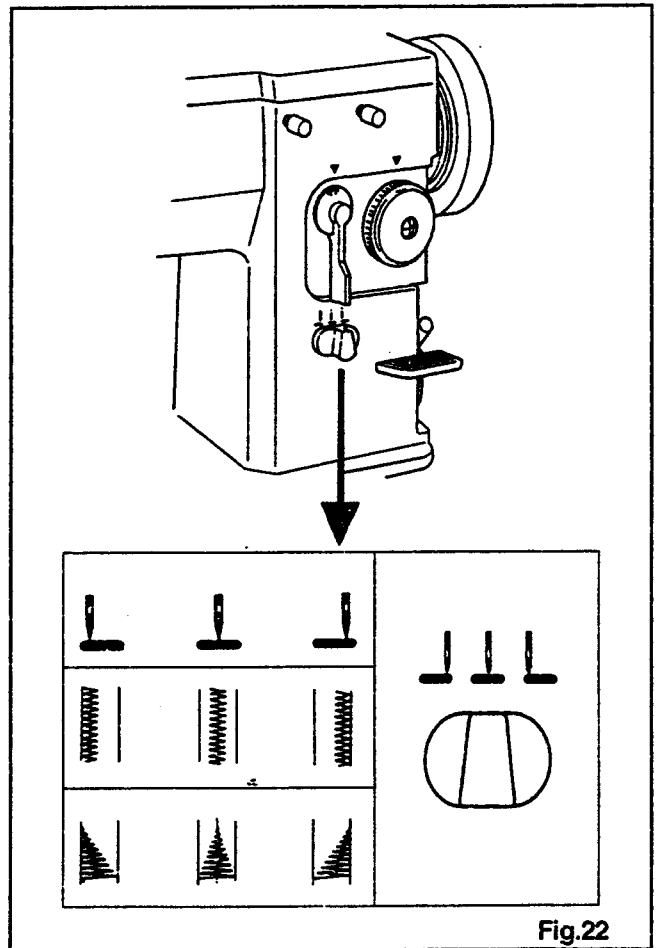

Fig.22



CAUTION

Switch off the machine.

Left, Center and Right needle position. settings are available for placement of both straight and zigzag stitching. (See Fig.22)

To position, push lever in and move to desired setting.

Do not make any needle position adjustment while the needle is in the fabric.

19. STITCH WIDTH REGULATOR

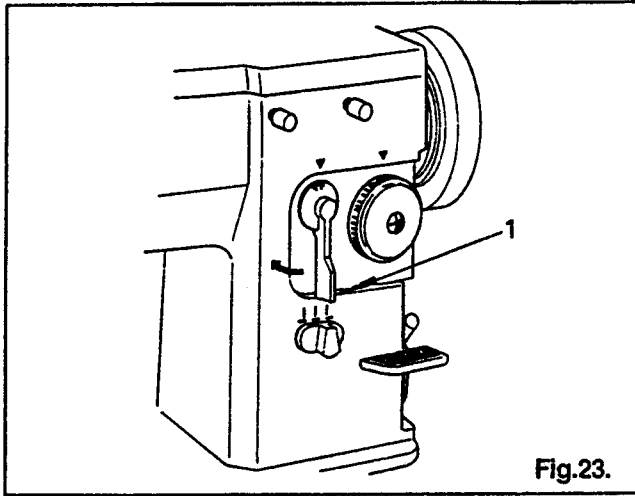

Fig.23.

The width of zigzag stitch is controlled with the spring biased stitch width regulating lever(1), Fig.23.

Maximum zigzag width: 0-9 mm

Do not make any needle position adjustment while the needle is in the fabric.

20.HOW TO CONTROL THE WIDTH OF ZIGZAG STITCH

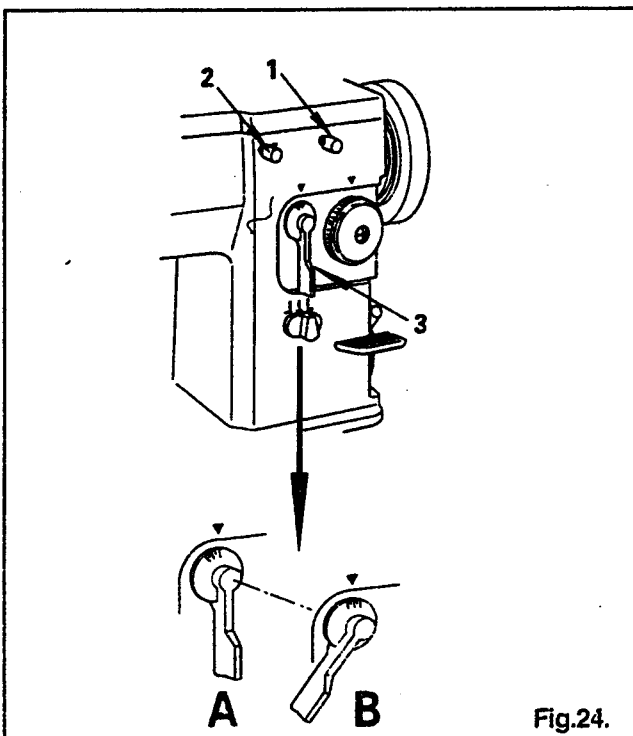

Fig.24.

To obtain minimum to maximum width zigzag stitches, first loosen thumb screw (2) ,Fig.24, to permit the stitch width regulator (3) , Fig.24 to return to its zero position (see A, Fig.24) and retighten thumb screw (2).

Then loosen thumb screw (1), Fig.24, turn stitch width regulator (3) clockwise as far as it will go and while holding the regulator (3) in this position (see B, Fig.24), retighten thumb screw (1).

You can now regulate the stitch width regulator within the range of zero to maximum.

21.NEEDLE BAR FRAME CLAMPING DEVICE

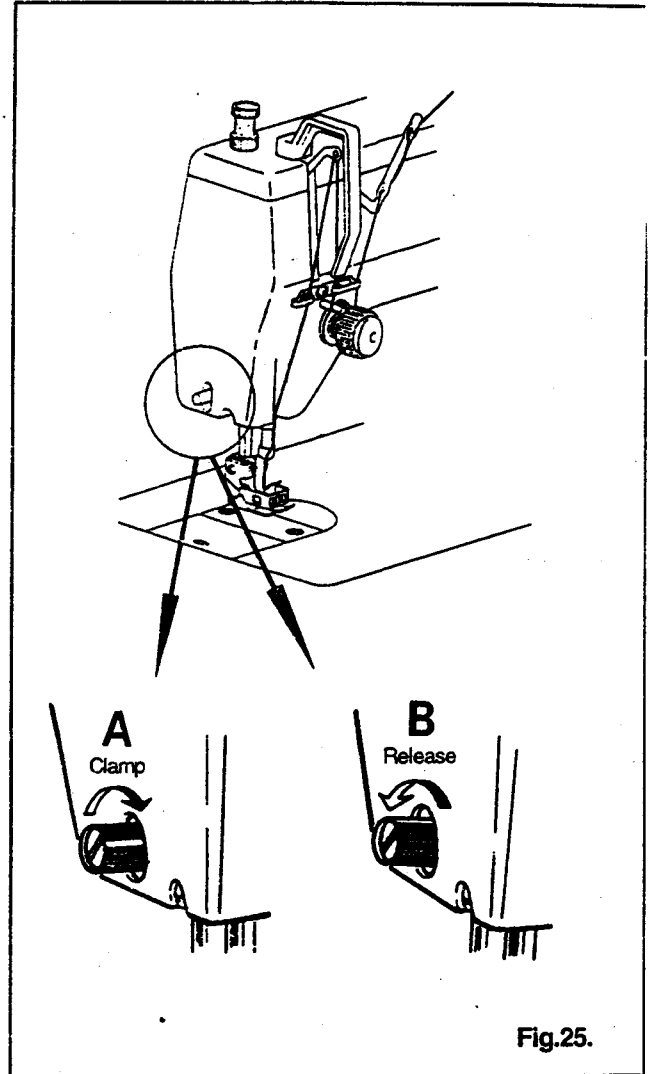
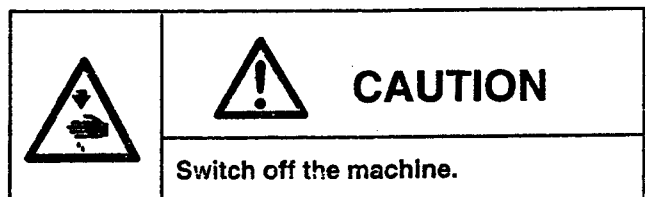

Fig.25.



When straight stitching, a better sewing result can be obtained by locking the needle bar frame immovable with the clamping device. (See Fig.25)

A:Clamp
B:Release

22.FITTINGS FOR STRAIGHT AND ZIGZAG STITCHING

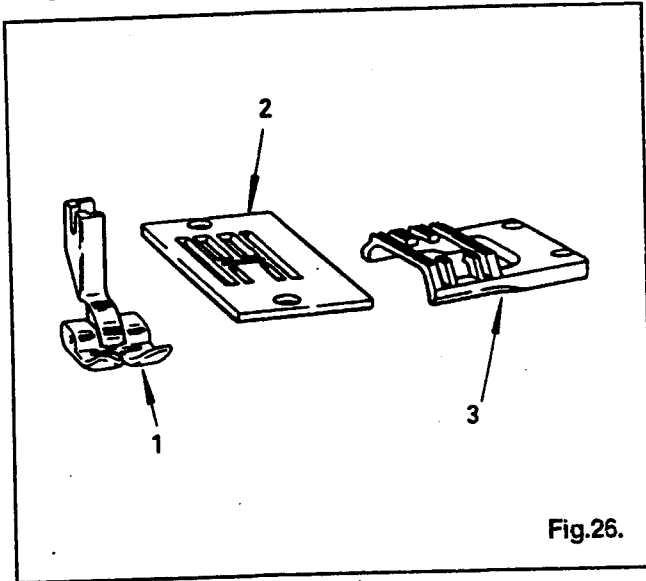

Fig.26.

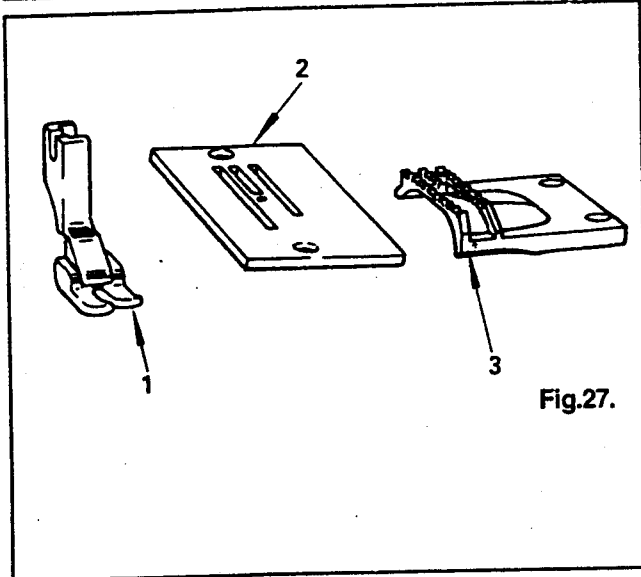

Fig.27.

General Purpose Presser Foot (1), Throat Plate (2) and Feed Dog (3) as shown in Fig.26, are used for straight and zigzag stitching.

Straight Stitch Presser Foot (1), Throat Plate (2) and Feed Dog (3) as shown in Fig.27, are used for straight stitching only.

23.CHANGING THE THROAT PLATE AND FEED DOG

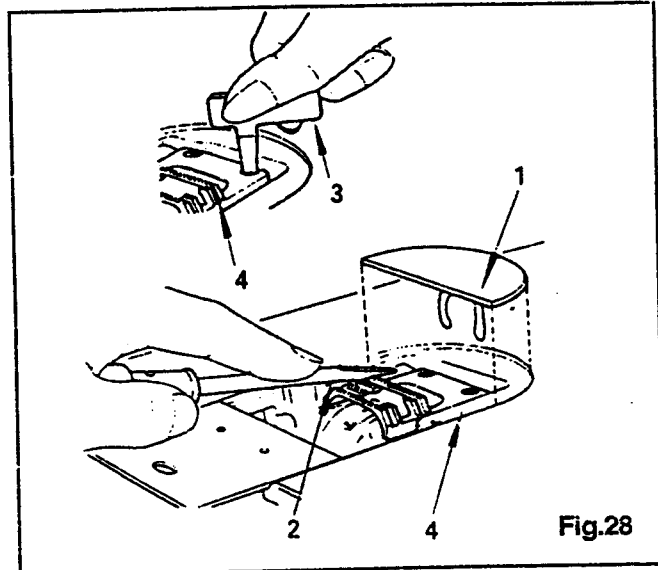

Fig.28



CAUTION

Switch off the machine.

1. Open bed slide, then remove throat plate. (Use screwdriver (3), Fig.28, furnished with machine for removal and replacement of throat plate and feed dog.)
2. Using a screwdriver (2), remove bed plate (1) and remove feed dog (4). (See Fig.28.)
3. To replace general purpose or straight stitch feed dog, fasten feed dog to machine temporarily and replace general purpose or straight stitch throat plate. Set feed dog correctly in position so that it will not hit the edge of feed dog slots in the throat plate.
4. Replace bed plate and press it firmly in place.

24. TO MOUNT THREAD UNWINDER

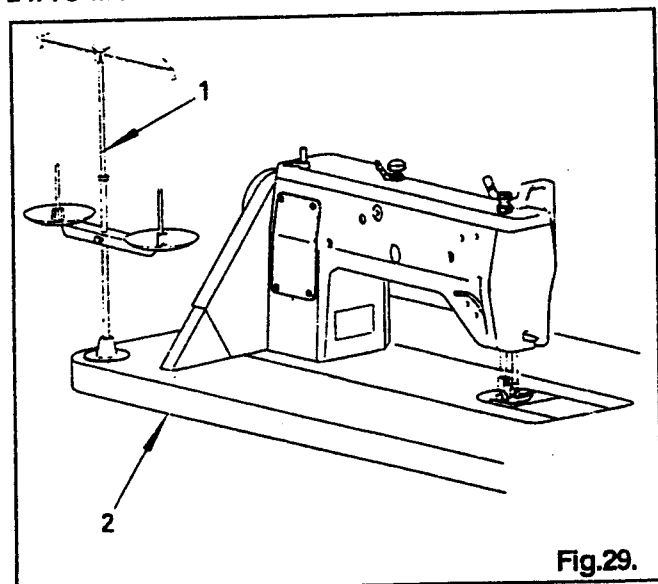

Fig.29.

Fix the thread (1) guide stand on table (2) plate.

25. TO USE THE SPOOL CAP

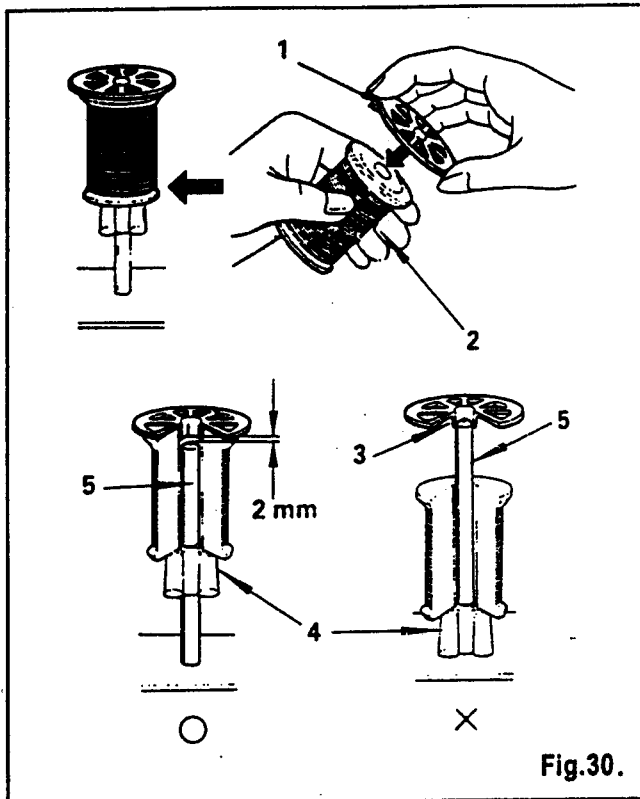

Fig.30.

When using a reel type thread spool, fit the spool cap (1) supplied with the machine onto the thread spool (2). Fig.30.

Set height of spool rest (4) so there is approximately 2mm clearance between top end of spool pin (5) and the tip of the slotted spigot (3) of the spool cap. (See Fig.30)

The spool cap should never be fitted on the spool pin. Forcing it onto the spool pin may result in breaking the slotted spigot of the spool cap. (See Fig.30)

26. TO USE THE ANTI-SPILL SLEEVE

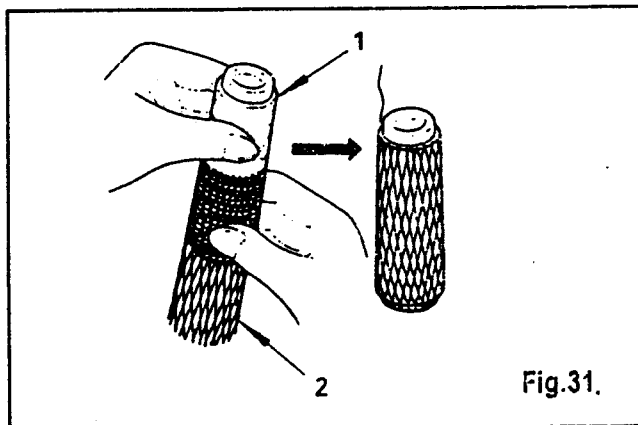

Fig.31.

When using synthetic threads that easily spill off the core (1), slip the anti-spill sleeve (2) furnished with the machine over the thread from the bottom of cone (1) leaving the thread end to hang free at the top of anti-spill sleeve (2) as shown in Fig.31.

27. KNEE LIFTER

TO MOUNT KNEE LIFTER

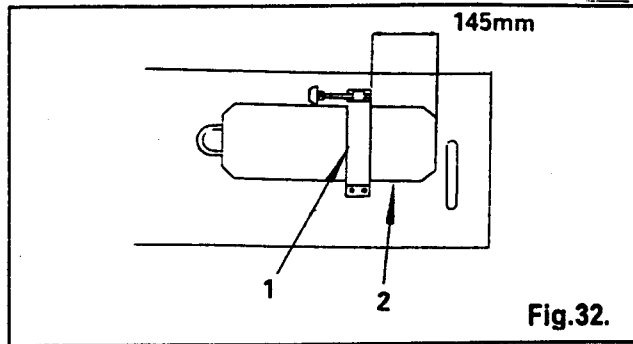

Fig.32.

Fasten knee lifter bracket (1) to underside of table (2) 145 mm from table cut-out as shown in Fig.32.

KNEE OPERATING PRESSER FOOT LIFT

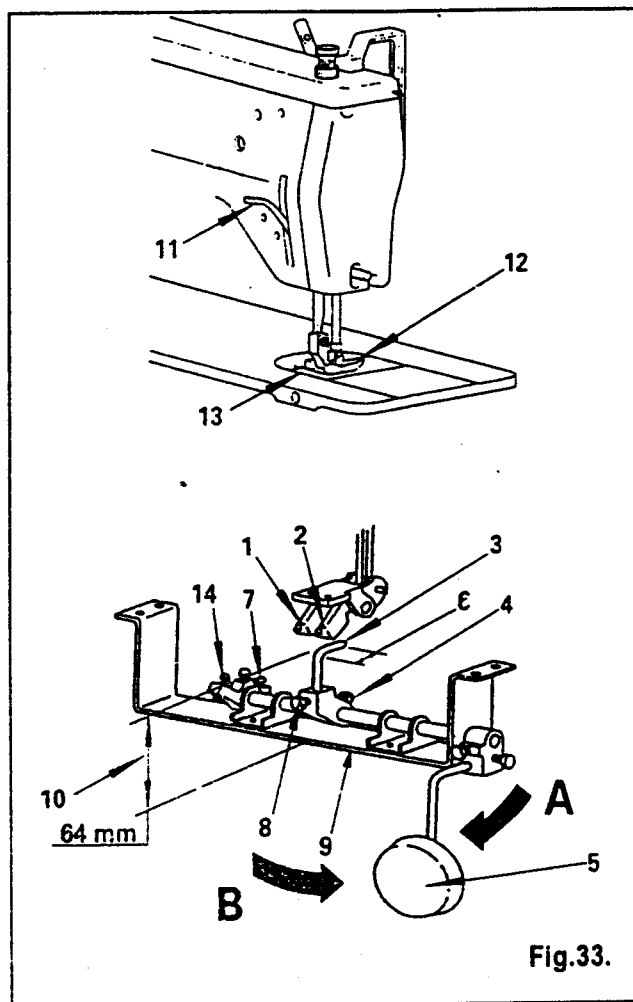

Fig.33.

	<h3>CAUTION</h3>
	<p>Switch off the machine. Set sewing head upright again using both hands. Danger of crushing between sewing head and table top.</p>

Bell cranks (1) and (2) shown in Fig.33 are fastened to the underside of the bed. Bell crank (1) is used for lifting and lowering the presser foot with knee, and bell crank (2) is used for controlling the stitch width. (See Fig.33)

To raise or lower the presser foot with knee, loosen screw (4) holding the knee lifter shaft arm (3) and move knee lifter shaft arm (3) just under the bell crank (1), and firmly tighten screw (4), (See Fig.33)

Loosen the lock nut holding screw (7) and turn screw (7) as required, so that the bent end (6) of knee lifter shaft arm (3) will be almost horizontal when knee lifter knee plate (5) is pushed as far as it will go in the direction indicated with arrow (A), then firmly tighten the lock nut. (See Fig.33)

With knee lifter shaft arm (3) set in position as described above, loosen screw (8) and move knee lifter shaft arm (3) up or down as required, so that height (10) from its bent end (6) to bracket (9) is 64 mm. (See Fig.33)

Raise presser foot (12) with presser foot lifter (11). Then loosen the lock nut holding screw (14) and turn screw (14) as required, so that knee lifter knee plate (5) when pushed in the direction indicated with arrow (B), will stop at a point (presser foot (12) raised approx. 9 mm from throat plate (13) surface) where presser bar lifter (11) will drop down from its raised position when presser bar is lifted a little higher than its normal up position. Then firmly tighten the lock nut. (See Fig.33)

When knee lifter knee plate (5) is pushed in the direction indicated with arrow (B), the presser foot (12) will rise and when knee plate (5) is released, presser foot (12) will be lowered. (See Fig.33)

KNEE OPERATING STITCH WIDTH CONTROL

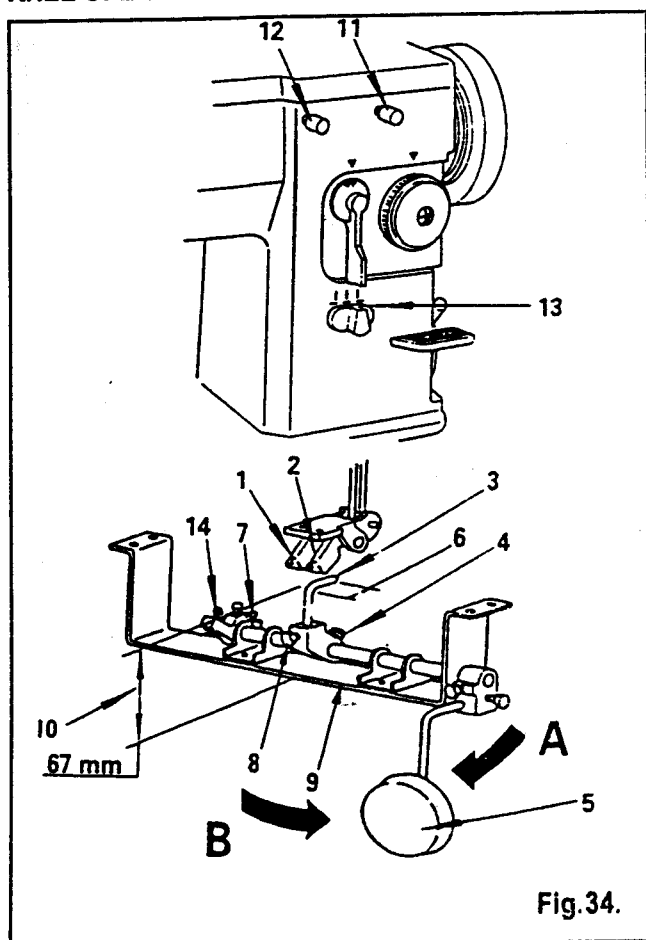
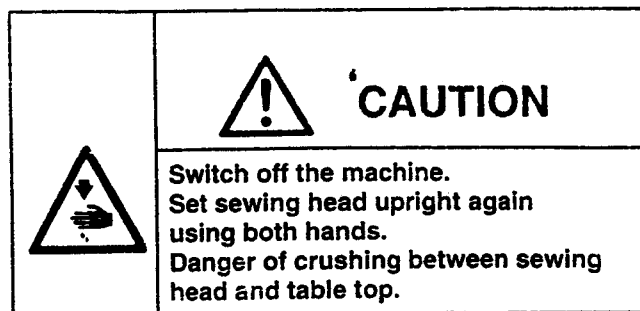

Fig.34.



Bell cranks (1) and (2) shown in Fig.34 are fastened to the underside of the bed. Bell crank (1) is used for lifting and lowering the presser foot with knee and bell crank (2) is used for controlling the stitch width.

To control the stitch width with knee, loosen screw (4) holding the knee lifter shaft arm (3) and move knee lifter shaft arm (3) just under the bell crank (2) and firmly tighten screw (4). (See Fig.34)

Loosen the lock nut holding screw (7) and turn screw (7) as required, so that the bent end (6) of knee lifter shaft arm will be almost horizontal when knee lifter knee plate (5) is pushed as far as it will go in the direction indicated with arrow (A). Then firmly tighten the lock nut. (See Fig.34)

With knee lifter shaft arm (3) set in position as described above, loosen screw (8) and move knee lifter shaft arm (3) up or down as required, so that height (10) from its bent end (6) to bracket (9) is 67 mm. (See Fig.34)

Loosen stitch width regulating plate thumb screws (11) and (12) so that stitch width regulator (13) can be moved from zero to maximum stitch width. (See Fig.34) Loosen the lock nut holding screw (14) and turn screw (14) as required, so that knee lifter knee plate (5) when pushed in the direction indicated with arrow (B), will stop at the maximum stitch width position of stitch width regulator (13). Then firmly tighten the lock nut. (See Fig.34)

Stitch width will become wider when knee lifter knee plate (5) is pushed in the direction indicated with arrow (B) and will become smaller when knee plate is released, (See Fig.34)

28. FITTINGS FOR BUTTONHOLE STITCHING

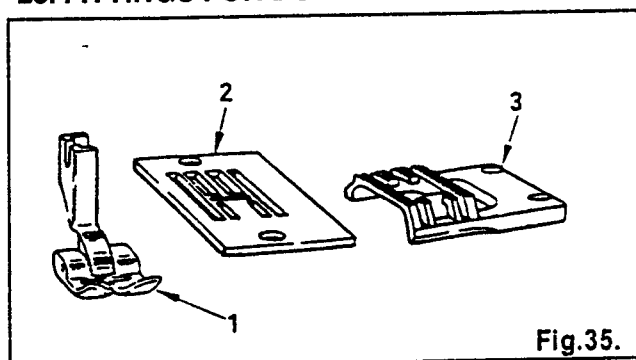
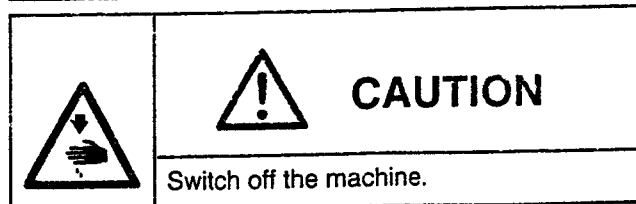

Fig.35.



Buttonhole Foot (1). General Purpose Throat Plate (2) and Feed Dog (3) as shown in Fig.35 are used for buttonhole stitching.

29. FITTINGS FOR HEM SEWING

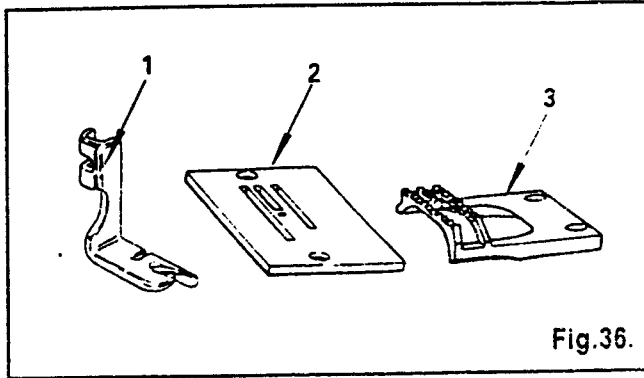
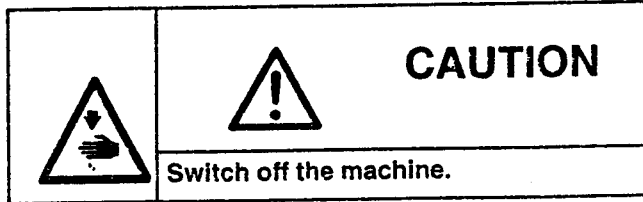

Fig. 36.



Hemmer Foot (1), Straight Stitch Throat Plate (2) and Feed Dog (3) as shown in Fig. 36 are used for hem sewing.

30. FITTINGS FOR ZIPPER AND CORD SEWING

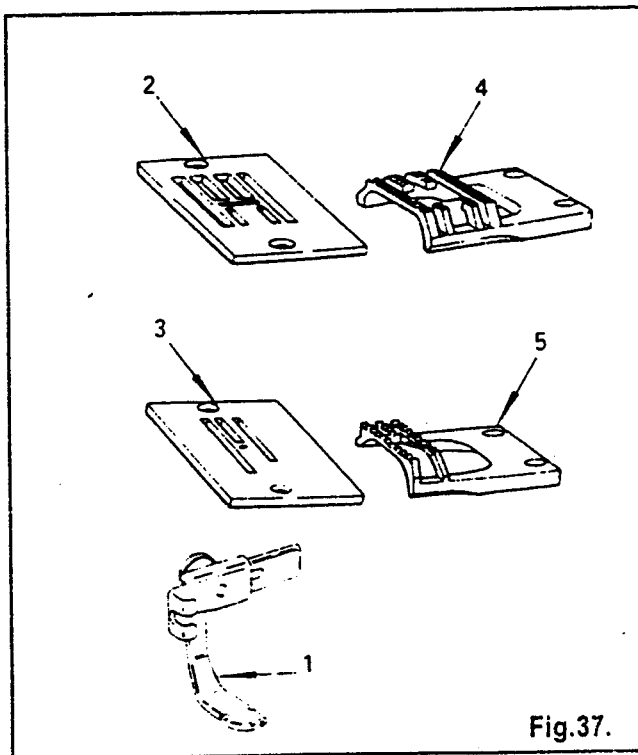
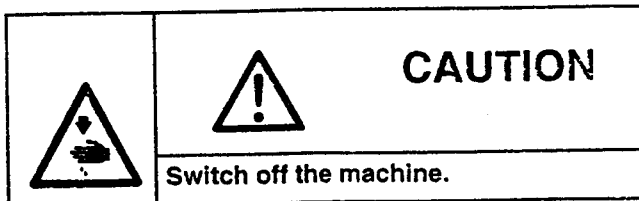

Fig. 37.



Zipper Foot (1), General Purpose (2) or Straight Stitch (3) Throat Plate and General Purpose (4) or Straight Stitch (5) Feed Dog as shown in Fig. 37 are used for zipper and cord sewing.

31. CARING FOR YOUR MACHINE

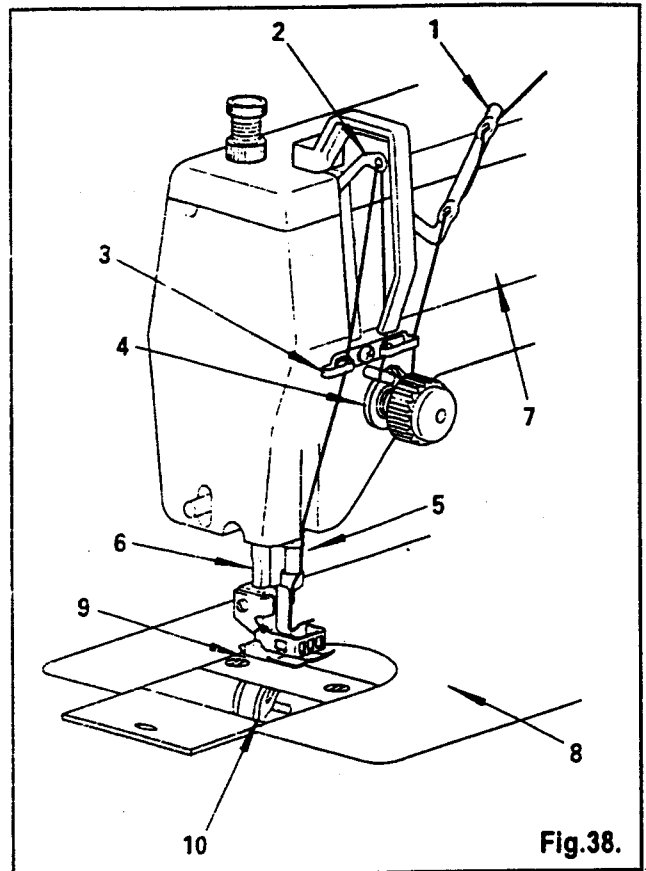
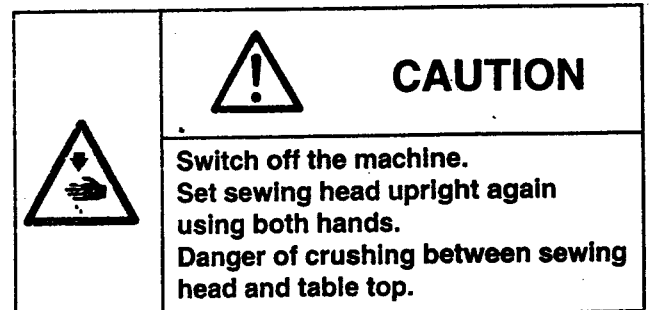

Fig. 38.



The machine will serve you perfectly for many years if you take a few moments of your time to keep it clean. How often you will need to clean and lubricate the machine will depend on how often you will use it.

When in regular use, the machine should be cleaned periodically to remove lint and fluff which may have accumulated around the working parts. A machine in continuous use should be oiled frequently, especially when the machine is operated at maximum recommended speed.

With a soft cloth, clean; (See Fig. 38)

- (1) Thread retainer
- (2) Take-up lever
- (3) Thread guard
- (4) Tension discs
- (5) Needle bar
- (6) Presser bar
- (7) Machine arm and bed

With a lint brush, clean; (See Fig. 38)

- (9) Feed dog
- (10) Rotating hook and area under throat plate. Turn hand wheel over toward you until oil hole in rotating hook appears in sight. Apply one or two drops of oil to the oil hole.

32. TROUBLESHOOTING CHART

Whenever sewing difficulty is encountered, check and make adjustments as follows.

Problem	Cause	Solution
Needle thread breaks	1. Is machine properly threaded? 2. Are thread guides or tension disc area lint-free? 3. Is needle-thread tension too tight? 4. Is needle bent or have a blunt point? 5. Is needle inserted correctly? 6. Is needle the correct size for the thread and fabric? 7. Is thread free of slubs and knots?	1. Correct needle threading 2. Remove lint and fluff in bobbin case and hook 3. Adjust needle thread tension 4. Insert new needle 5. Insert needle correctly 6. Select proper needle size and thread 7. Remove slubs and knots
Bobbin thread breaks	8. Is bobbin threading correct? 9. Is thread tangled or caught? 10. Is thread tension correct? 11. Does bobbin rotate smoothly?	8. Correct bobbin threading 9. Untangle thread from bobbin case and hook 10. Adjust needle and bobbin case thread tension 11. Check whether bobbin thread is wound correctly
Stitches skip	12. Is needle inserted correctly? 13. Is needle bent or have blunt needle point? 14. Is size of needle and thread suitable for fabric? 15. Is threading correct?	12. Insert needle correctly 13. Insert new needle 14. Select proper needle size and thread 15. Correct needle threading
Needle breaks	16. Is needle properly inserted? 17. Is needle bent? 18. Is needle the correct size for the fabric? 19. Is needle clamping screw loose? 20. Is the fabric pulled while sewing?	16. Insert needle correctly 17. Insert new needle 18. Select proper needle and thread for fabric 19. Tighten needle set screw 20. Do not pull fabric while sewing
Fabric fails to feed	21. Is feed regulating dial properly adjusted? 22. Is presser foot pressure adjusted properly?	21. Lengthen stitch length by feed regulating dial 22. Increase presser foot pressure
Fabric puckers	23. Is needle threading correct? 24. Is needle point blunt? 25. Is thread tension too tight?	23. Correct needle threading 24. Insert new needle 25. Adjust needle tension properly
Rotating head Noisy	26. Is there any lint or fluff on feed dog? 27. Is there any lint in rotating hook?	26. Remove lint and fluff from feed dog 27. Remove lint and fluff from rotating hook
Machine fails to start	28. Are electrical plugs properly connected? 29. Is power and light switch turned on?	28. Turn on power switch 29. Connect plug to power source

If you still have difficulty in sewing even after making adjustments, contact your nearest Service Center.

33. SPECIFICATIONS

Machine class	ZZ 509	
For sewing	Light medium	
Stitch type	301 Lockstitch, 304 (Zigzag lockstitch)	
Max. speed*	2,500r.p.m	
Max. stitch length	9.0 mm	
Needle bar stroke	5.0 mm	
Presser bar lift (manual)	34.8 mm	
presser bar lift	6.35 mm	
Presser bar lift (knee lifter)	9.0 mm	
Needle catalog (needle system)	CAT.1910-05(135X9)	
Needle size	See page 3 for table on "NEEDLE AND THREAD"	
Machine pulley	Effective dia. for V-belt 74 mm	
Workspace width	211 mm	
Workspace height	130 mm	
Bedplate dimensions	399 mm x 178 mm	
Net weight (head only)	19.5 kg	
Gross weight (with accessories)	21.0 kg	

* Maximum speed will vary depending on fabric, threads and sewing condition.

Relationship between zigzag bight and maximum speed

Machine class	ZZ 509	
Zigzag bight	0 mm ~ 5 mm	5 mm ~ 9 mm
Max. speed	2,500 r.p.m	2,000 r.p.m

GLOBAL

ZZ 509
Parts list

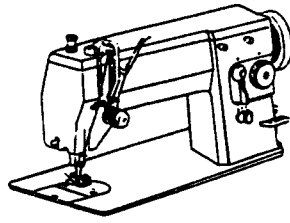

GS139-8



GR233-8

GS147-8

GR490/12-8

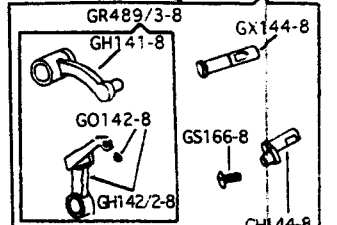

GR489/3-8

GH141-8

GO142-8

GH142/2-8

GX144-8

GS166-8

GH144-8

GS164-8

GX143-8

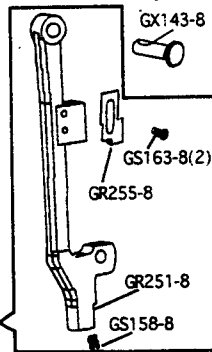

GZ223-8

GR251-8

GS158-8

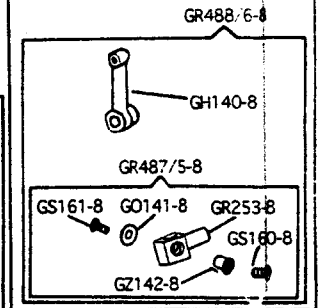

GR488/6-8

GH140-8

GR487/5-8

GS161-8

GO141-8

GR253-8

GS160-8

GZ142-8

GS375-8(2)

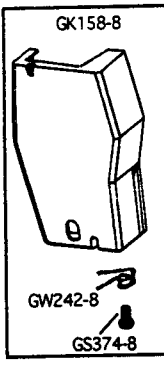

GK158-8

GW242-8

GS374-8

GS384-8

GL178-8

GW153-8

GZ187-8

GR231-8

GS223-8

GX180-8

GR523/2-8

GR398-8

GS232-8

GR486/6-8

GR485/5-8

GR397-8

GR373-8

GW135-8

GS148-8

GR484/4-8

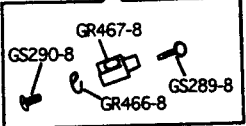

GR467-8

GS290-8

GR466-8

GS289-8

GS147-8

GR254-8

GO217-8(2)

GS132-8(2)

GR729/11-8

GR478/2-8

GS146-8

GR372-8

GX132-8

GW134

GR237

GR733-8

GS232-8

GX183-8

GS231-8

GR465/4-8

GR476/4-8

GM132-8

GW131-8

GS133-8

GR100-8

GR477/4-8

GM130-8

GW130-8

GS255-8(2)

GS134-8(2)

GM156-8

GR278-8

GN135-8

GS256-8

GS288-8

GW179-8

GX191-8

GN130-8

GN130-8

GT150-8

GS264-8

GR496/2-8

GL140-8

GS183-8

GR265-8

GR496/2-8

GL

GO164-8

GO165-8

GO164-8

GC141-8

GK130-8

GS132-8

GS201-8

GS202-8(2)

GS202-8(2)

GS167-8(2)

GS201-8

GO165-8

GZ164-8

GS184-8

GM161

GM161

GM161

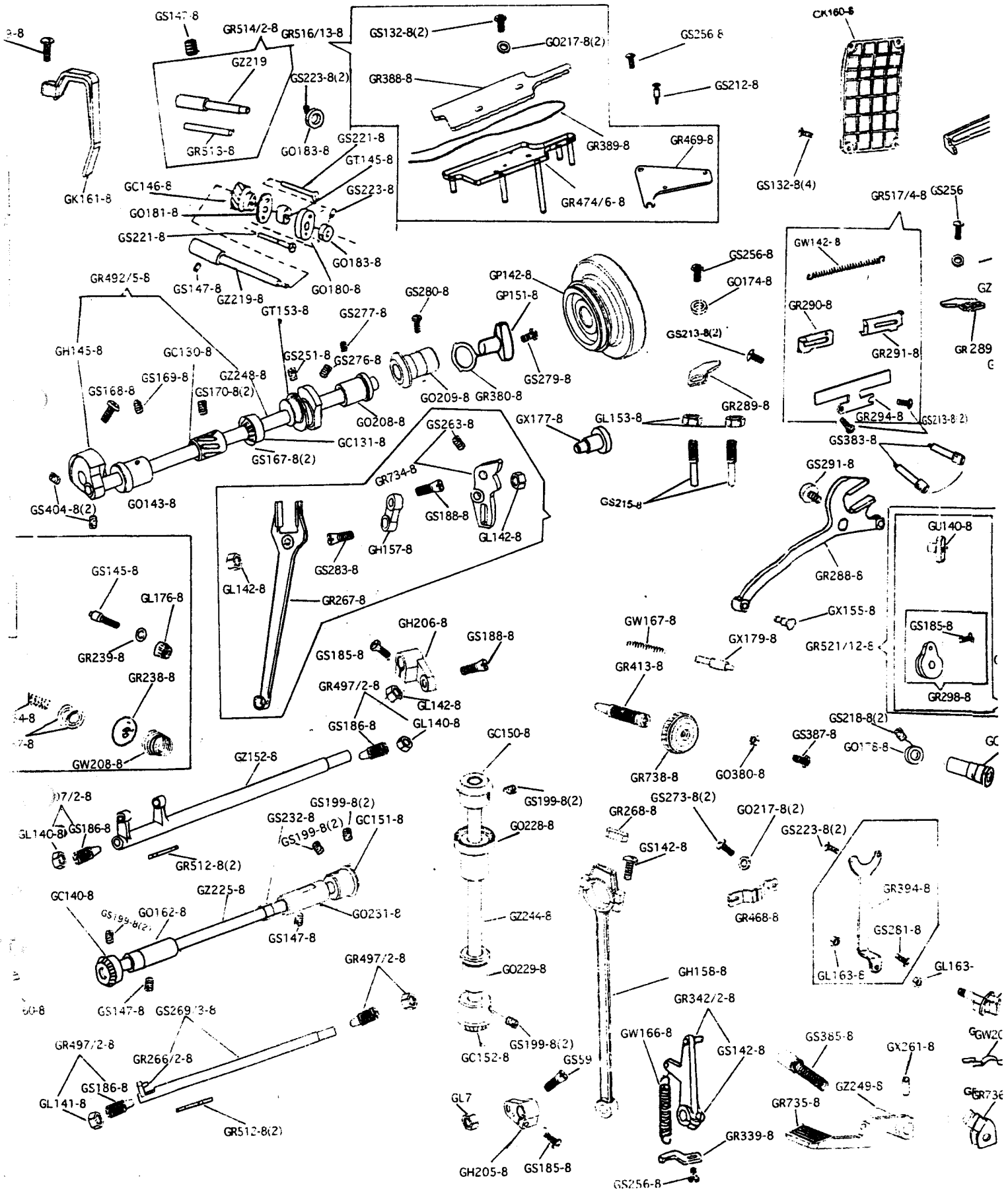

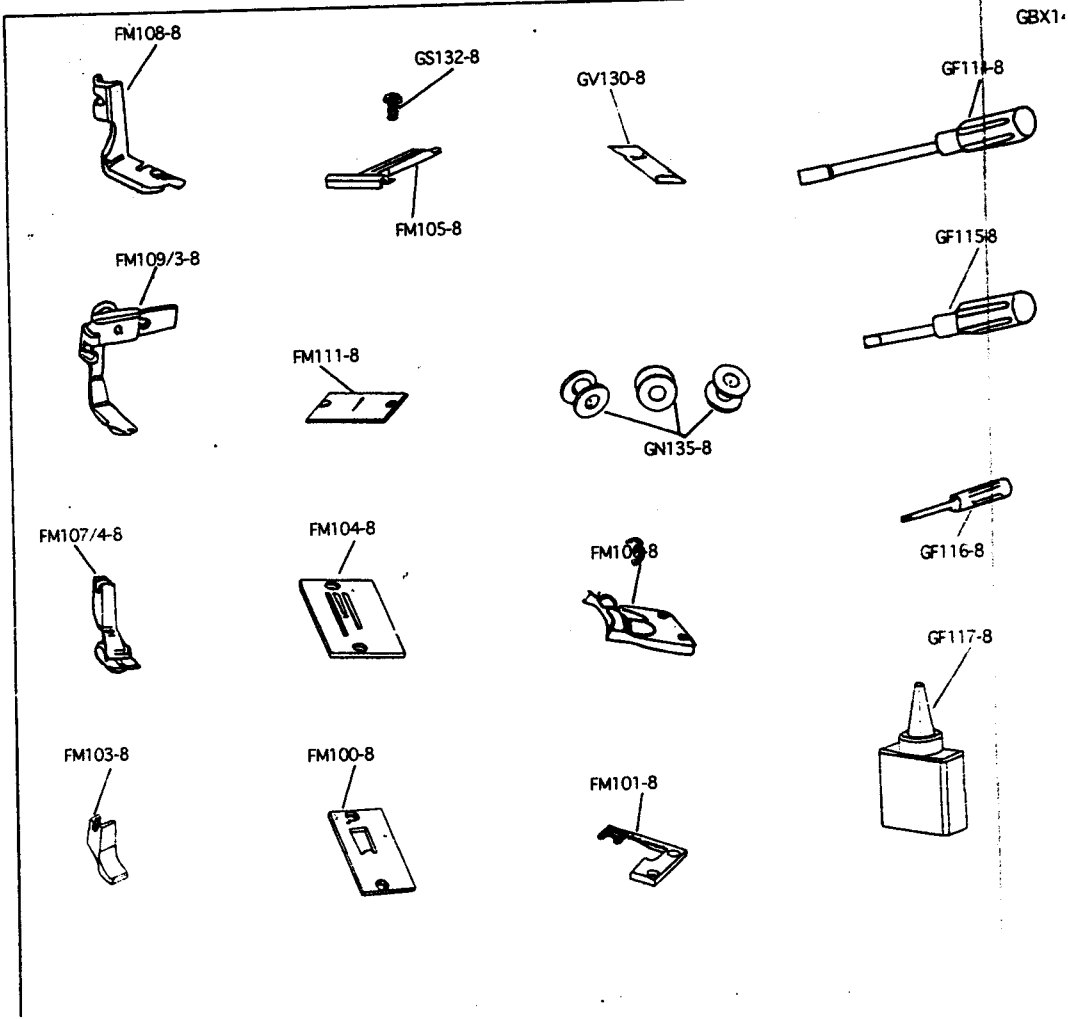
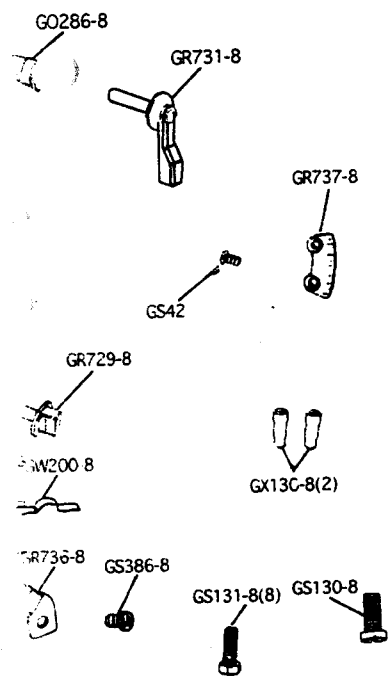
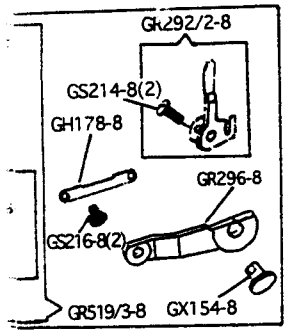
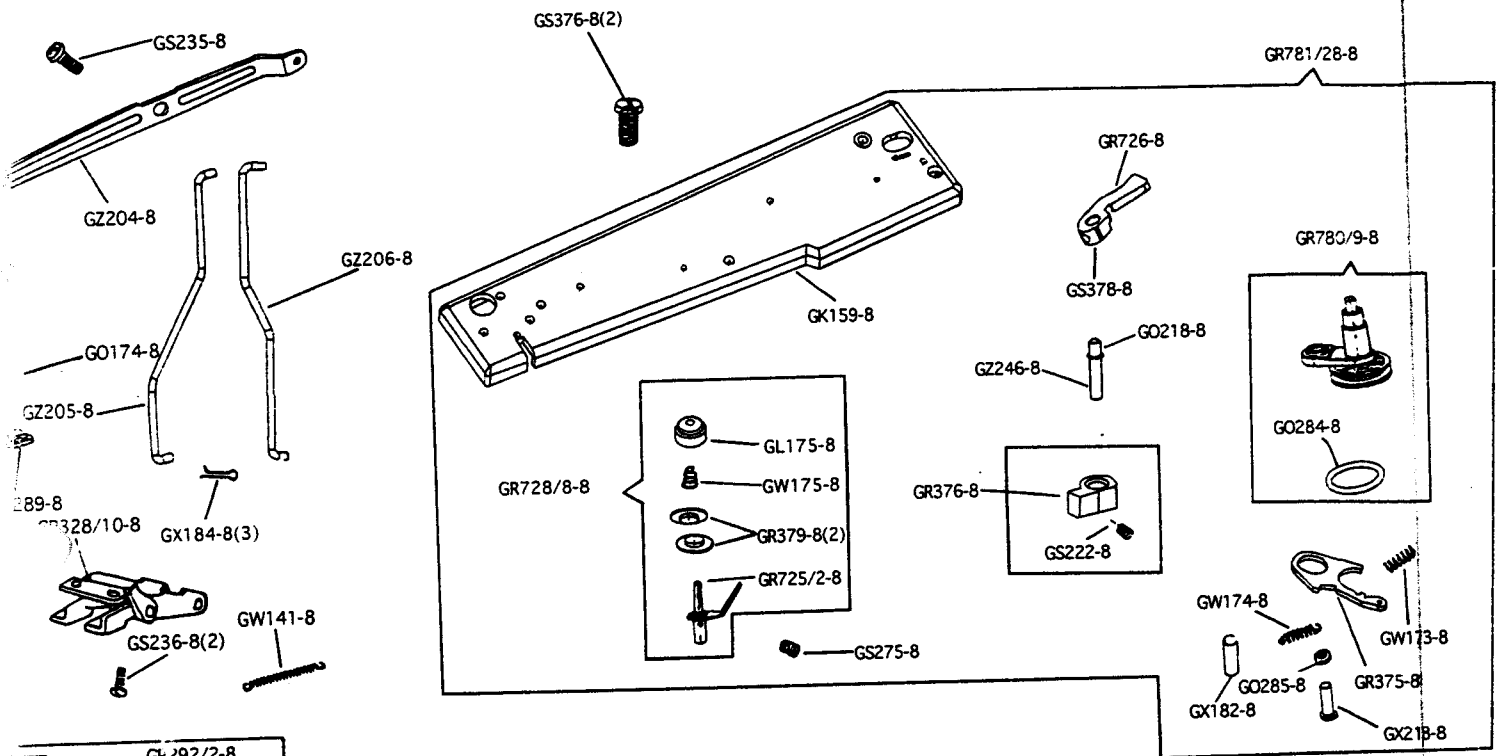

NUMERICAL LIST OF PARTS

<u>Part NO.</u>	<u>Description</u>	<u>Part NO.</u>	<u>Description</u>
GS276-8	Feed cam position screw	FM111-8	Emboidery plate
GO208-8	Upper shaft back bushing	FM107/4-8	Straight stitch foot
GZ248-8	Upper shaft	FM104-8	Straight stitch throat plate
GO209-8	Hand wheel shaft bushing	FM103-8	Straight stitch feed dog
GS280-8	hand wheel shaft bushing screw	GV130-8	Needle
GP142-8	Hand wheel	GN135-8	Bobbin
GR380-8	Clutch wash	GF114-8	Screwdriver (L)
GP151-8	Clutch hand wheel	GF115-8	Screwdriver (M)
GS279-8	Small clutch screw	GF116-8	Screwdriver (S)
GV130-8	Needle	GF117-8	Oiler
GS277-8	Upper shaft back bushing	GR788-8	T-type open knife
GS200-8	Hand wheel set screw (2)	GR790-8	Anti-spill sleeve
GS142-8	Feed bar lifting link screw	GR789-8	Spool cap
GR268-8	Oil felt	GM172-8	Buttonhole foot
GH158-8	Feed bar lifting link	GS256-8	Rotating hook position plate screw
GS59-8	Small cone nut	GR278-8	Rotating hook position plate
GH157-8	Stich regulator block connecting link	GN131-8	Bobbin case
GL142-8	Small cone nut	GN135-8	Bobbin
GL141-8	Feed rock shaft centre nut	GN130-8	Rotating hook
GS186-8	Feed rock shaft centre screw	GO163-8	Front bushing of rotating hook shaft
GH206-8	Feed rock shaft crank	GS201-8	Front bushing screw of rotating hook shaft
GS185-8	Feed crank screw	GO164-8	Retainer of rotating hook shaft(2)
GS184-8	Feed dog screw	GS202-8	Retainer screw of rotating hook shaft(4)
GM160-8	Feed dog	GO165-8	Back bushing of rotating hook shaft
GL140-8	Feed bar centre nut	GS201-8	Back bushing screw of rotating hook shaft
GS183-8	Feed bar centre screw	GZ164-8	Rotating hook shaft
GZ152-8	Feed rock shaft	GS167-8	Rotating hook shaft bevel gear screw (2)
GR265-8	Feed bar	GC141-8	Rotating hook shaft bevel gear
GR269/3-8	Feed bar lifting crank assembly	GC140-8	Lower shaft bevel gear
GS185-8	Feed bar lifting crank screw	GS199-8	Lower shaft bevel gear screw (2)
GH205-8	Feed bar lifting crank	GO162-8	Front bushing of lower shaft
GR512-8(2)	Oil braid	GS147-8	Front bushing screw of lower shaft
GR267-8	Feed fork	GZ225-8	Lower shaft
GS283-8	Feed fork centre screw	GO232-8	Retainer of lower shaft
	Thread unwinder complete	GS199-8	Retainer screw of lower shaft(2)
GR1315/18-8	Knee lifter complete	GO231-8	Back bushing of lower shaft
GR527-8	Hand wheel cover	GS147-8	Back bushing screw of lower shaft
GBS204-8	Back cover of hand wheel	GC151-8	Lower shaft bevel gear
GS293-8	Back cover of hand wheel screw	GS199-8	Lower shaft bevel gear screw (2)
GS360-8	Hand wheel cover screw	GS199-8	Bevel gear screw of vertical shaft(2)
GBR204-8	Machine head cushion	GC152-8	Vertical shaft Bevel gear
GBR205-8	Machine head cushion	GO229-8	Lower bushing of vertical shaft
GBS202-8	Machine head cushion nail	GZ224-8	Vertical shaft
GBS201-8	Oil reservoir nail	GO228-8	Upper bushing of vertical shaft
GR413-8	Oil reservoir	GS199-8	Bevel gear screw of vertical shaft(2)
GBR203-8	Machine head pole	GC150-8	Vertical shaft Bevel gear
GR353-8	Machine head hinge cushion rubber	GR288-8	Zigzag stitch regulator fork
GBX140-8	Machine head hinge cushion rubber nail	GZ219-8	Zigzag triangular cam shaft
GR352/2-8	Machine head hinge complete	GS147-8	Screw of zigzag triangular cam shaft
FM108-8	Hemmer foot	GC146-8	Zigzag triangular camgear
GS132-8	Hwm edge guide screw	GO181-8	Eccentric stop ring
FM105-8	Hem edge guide	GS221-8	Zigzag eccentric cam connecting screw(2)
FM109/3-8	Zipper foot complete	GT145-8	Zigzag eccentric cam

NUMERICAL LIST OF PARTS

<u>Part NO.</u>	<u>Description</u>	<u>Part NO.</u>	<u>Description</u>
GK158-8	Face plate	GR780/9-8	Thread winding shaft assembly
GR242-8	Face plate thread guard	GO284-8	Rubber ring
GS374-8	Face plate thread guard screw	GR375-8	Thread winding swaying handle
GS375-8	Face plate screw (2)	GX218-8	Thread winding crank pin
GK161-8	Thread take-up guard	GS275-8	Thread winding crank pin screw
GS379-8	Thread take-up guard screw	GW173-8	Thread winding swaying handle pressing spring
GK160-8	Back cover	GW174-8	Thread winding swaying handle extension spring
GS132-8	Back cover screw (4)	GX182-8	Extension spring pin
GR233-8	Thread retainer	GR376-8	Thread winding locating block
GS139-8	Thread retainer screw	GS222-8	Thread winding locating block set screw
GR231-8	Thread guard	GO285-8	Thread winding swaying handle cushion
GS223-8	Thread guard screw	GR726-8	Volume-adjusting plate
GX180-8	Thread sliding shell	GS378-8	Volume-adjusting plate screw
GT150-8	Linear lock eccentric cover	GZ246-8	Thread winding shaft
GS264-8	Linear lock eccentric cover screw	GO218-8	Thread winding shaft stop ring
GK130-8	Rotating hook guard plate	GS164-8	Pin screw of needle bar vibrating lever
GS132-8	Rotating hook guard plate screw	GR251-8	Needle bar vibrating lever
GM156-8	Throat plate	GS158-8	Eccentric pin screw of needle bar
GS338-8	Throat plate screw (2)	GR255-8	Needle bar position plate
GR476/4-8	Slide plate assembly	GS163-8	Needle bar position plate screw (2)
GM132-8	Slide plate	GX143-8	Pin of needle bar vibrating lever
GW131-8	Slide plate spring	GZ223-8	Needle bar
GS133-8	Slide plate spring screw (2)	GR467-8	Needle clamp
GR477/4-8	Bed plate assembly	GS290-8	Screw of thread guard
GM130-8	Bed plate	GR466-8	Needle bar thread guard
GW130-8	Bed plate spring	GS289-8	Needle set screw
GS255-8	Bed plate spring screw (2)	GS161-8	Pin screw of needle bar clamp
GR373-8	Thread tension releasing lever	GO141-8	Pin washer of needle bar clamp
GW135-8	Thread tension releasing lever spring	GR253-8	Needle bar clamp
GS148-8	Thread tension releasing lever screw	GZ142-8	Pin of needle bar clamp
GR729/11-8	Thread tension assembly	GS160-8	Pin set screw of needle bar clamp
GL176-8	Thread tension nut	GR254-8	Needle bar connecting link guide
GR239-8	Thread holding brake	GO217-8	Needle bar connecting link guide washer(2)
GW208-8	Thread tension spring	GS132-8	Needle bar connecting link guide screw
GR238-8	Thread tension releasing disc	GS166-8	Left-hand thread screw
GR237-8	Thread tension disc(2)	GH140-8	Needle bar connecting link
GS145-8	Thread tension post	GH144-8	Needle bar crank
GW134-8	Thread take-up spring	GH142/2-8	Thread take-up lever assembly
GR372-8	Thread take-up spring adjusting base	GO142-8	Thread guide ring
GS146-8	Thread tension post set screw	GH141-8	Thread take-up rocker
GS147-8	Thread tension assembly set screw	GX144-8	Thread take-up rocker pin
GX132-8	Thread tension releasing pin	GS147-8	Thread take-up rocker pin screw
GX191-8	Eccentric cover supporting pole	GS168-8	Thread take-up crank screw
GW179-8	Eccentric cover pressing spring	GH145-8	Thread take-up crank
GS288-8	Pressing spring screw	GS404-8	Needle bar crank set screw (2)
GK159-8	Upper cover	GO143-8	Upper shaft
GS376-8	Upper cover screw	GS277-8	Upper shaft set screw
GR728/8-8	Upper thread tension retainer	GC130-8	Upper shaft spiral gear
GR725/2-8	Upper thread retaining plate	GS170-8	Upper shaft spiral gear screw (2)
GR379-8	Upper thread tension disc(2)	GC131-8	Upper shaft bevel gear
GW175-8	Upper thread tension spring	GS167-8	Upper shaft bevel gear screw (2)
GL175-8	Upper thread tension nut	GT153-8	Feed cam
GS275-8	Upper thread tension post set screw	GS251-8	Feed cam set screw

NUMERICAL LIST OF PARTS

Part NO.	Description	Description
GO180-8	Back stop ring of Zigzag eccentric cam	GW153-8 Presser bar spring
GS223-8	Stop ring screw of Zigzag triangular cam shaft (2)	GZ187-8 Presser bar
GO183-8	Stop ring of Zigzag triangular cam shaft	GS231-8 Presser foot screw
GW142-8	Bight amplitude regulating plate spring	GR465/4-8 Presser foot complete
GR469-8	Oil pan plate	GR733-8 Presser foot lifter
GX155-8	Zigzag stitch regulator fork eccentric	GS232-8 Presser foot lifter pin screw
GU140-8	Bight amplitude slide block	GX183-8 Presser foot lifter pin
GR298-8	Bight amplitude slide block guide	GS232-8 Presser bar guide bracket set screw
GS185-8	Bight amplitude slide block guide stud set screw	GR398-8 Presser bar guide bracket
GH178-8	Bight amplitude slide block crank link	GR397-8 Presser bar lifting and releasing lever bracket
GS216-8	Bight amplitude slide block crank link hinge(2)	GR328/10-8 Bell crank complete
GR296-8	Bright and L-C-R position lever arm	GS236-8 Knee lifter lever bracket screw
GX154-8	Bight amplitude slide block guide stud	GX184-8 Open pin
GS215-8	Bight and L-C-R position lever arm regulating screw(2)	GZ205-8 Lifting lever connecting rod
GL153-8	Bight and L-C-R position lever arm regulating nut(2)	GZ206-8 Bight amplitude slide block crank knee operating connection
GS214-8	Bight amplitude slide block crank set screw(2)	GS235-8 Lifting lever hinge screw
GW141-8	Bight amplitude slide block crank return spring	GZ204-8 Lifting lever
GR292/2-8	Bight amplitude slide block crank complete	GR1000-8 Needle guard
GS218-8	Bight amplitude slide block crank shaft bushing collar set screw(2)	GS413-8 Feed regulating stud
GO178-8	Bight amplitude slide block crank shaft bushing collar	GX177-8 Feed regulator hinge stud
GS291-8	Bight amplitude slide block cap screw	GS263-8 Feed regulator hinge stud set screw
GO286-8	Bight amplitude slide block crank shaft bushing	GR734-8 Feed regulator
GR731-8	Bight amplitude slide block crank shaft knob	GW166-8 Feed reverse lever return spring
GR468-8	Bight and L-C-R position block	GS256-8 Feed reverse lever return spring bracket screw
GS273-8	Bight and L-C-R position block set screw(2)	GR339-8 Feed reverse lever return spring bracket
GR729-8	Bight and L-C-R position lever complete	GR342/2-8 Feed reverse lever crank complete
GS281-8	Bight and L-C-R position lever screw pin	GS142-8 Feed reverse lever crank screw
GR394-8	Bight and L-C-R position lever	GZ249-8 Feed reverse lever hinge stud
GS223-8	Bight and L-C-R position lever set screw (2)	GR735-8 Feed reverse lever
GL163-8	Bight and L-C-R position lever screw pin nut (2)	GS385-8 Feed reverse adjusting screw
GR289-8	Bight amplitude stop plate (left)	GS387-8 Feed regulating dial stud
GR289-8	Bight amplitude stop plate (right)	Feed regulating dial stud washer
GO174-8	Bight amplitude stop plate washer(2)	GR738-8 Feed regulating dial
GS256-8	Bight amplitude stop plate screw (2)	GX179-8 Feed regulating stud lock pin
GS383-8	Bight amplitude regulating plate thumb screw(2)	GW167-8 Feed regulating stud lock pin spring
GS213-8	Bight amplitude regulating plate holder set screw(2)	GS42 Feed reverse regulating indicating-dial screw(2)
GR294-8	Bight amplitude regulating plate holder	GR737-8 Feed reverse regulating indicating-dial
GR290-8	Bight amplitude regulating plate (A)	GW200-8 Feed reverse regulating screw clamping spring
GR291-8	Bight amplitude regulating plate (B)	GR736-8 Feed reverse regulating plate
GS212-8	Oil reservoir plate set screw(front)	GS386-8 Feed reverse regulating plate screw
GS256-8	Oil reservoir plate set screw (back)	GX261-8 Feed reverse lever hinge stud
GR474/6-8	Oil reservoir complete	GR789-8 Thread Unwinder spool cap (2)
GR389-8	Oil wick	GR790-8 Thread Unwinder spool Net (2)
GR388-8	Oil reservoir felt	GR788-8 Screw Driver (for throat plate)
GO217-8	Oil reservoir set screw washer (2)	
GS132-8	oil reservoir set screw (2)	
GS384-8	Presser regulating thumb screw	
GL178-8	Presser regulating nut	

781/28-8

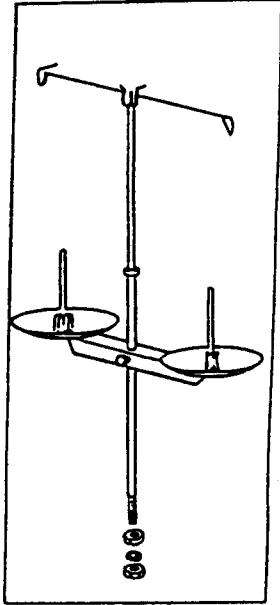
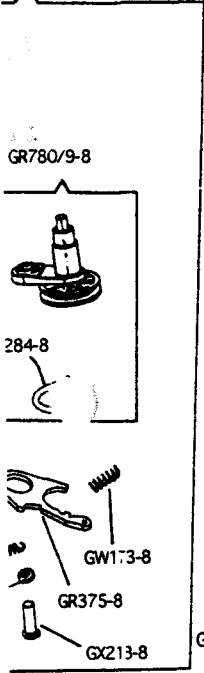

GR1316-8

GK155-8

GR527-8

GBR210-8

GBS204-8

GK156-8

GS360-8

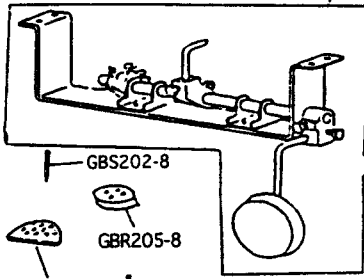

GR1315/18-8

GBS202-8

GBR205-8

GBR204-8

GBS201-8

GR352/2-8

GBX140-8

GR353-8

GR413-8

GBR211-8

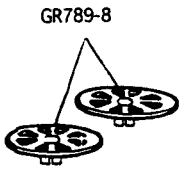
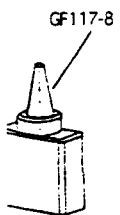
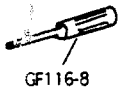
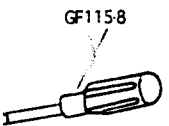
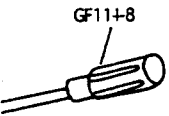

GF114-8

GF115-8

GF116-8

GF117-8

GR788-8

GR789-8

GK790-8